

KF 1500

Hafif metaller için vidalar
Screws for light metals

MC - LS 1500 Serisi
MC - LS 1500 Series

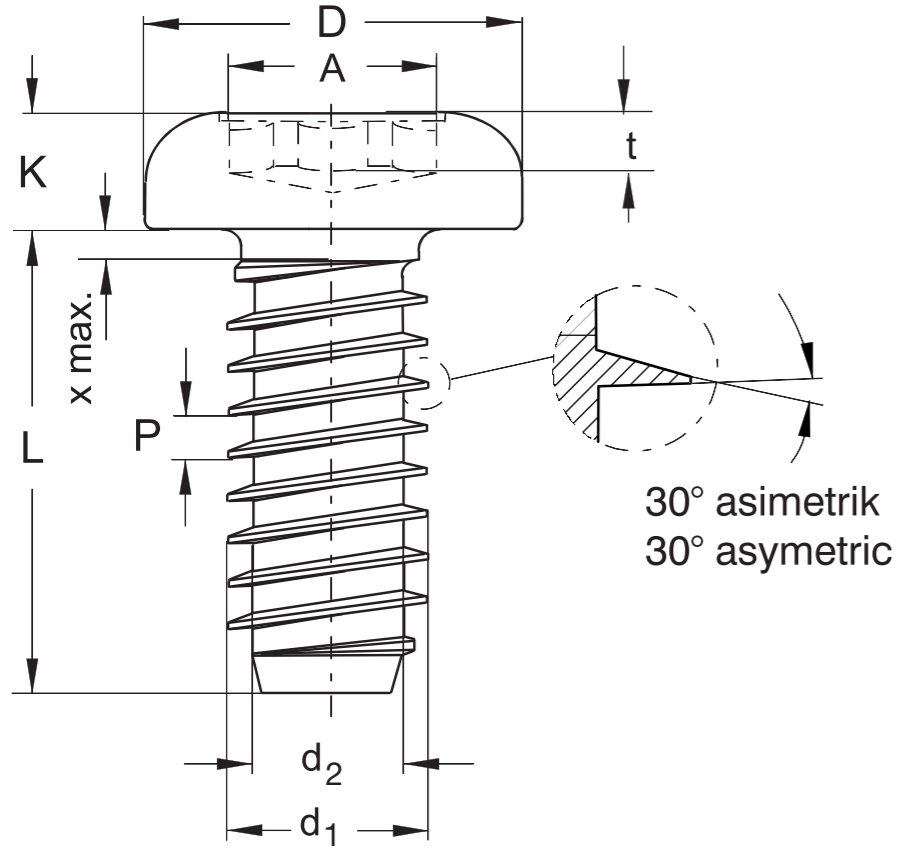

Diş Çapları - Nominal Diameter		LS 18	LS 22	LS 25	LS 30	LS 35	LS 40	LS 50	LS 60	LS 70	LS 80
Kafa Formları Head Forms	d1	1,80	2,20	2,50	3,00	3,50	4,00	5,00	6,00	7,00	8,00
	d2	1,33	1,59	1,81	2,18	2,56	2,93	3,68	4,42	5,21	5,91
	p	0,64	0,71	0,77	0,86	0,95	1,05	1,23	1,42	1,60	1,79
	x max	0,90	1,10	1,30	1,50	1,80	2,00	2,50	3,00	3,50	4,00
KF 1542	D	3,60	4,00	5,00	6,00	7,00	8,00	10,00	12,00	14,00	16,00
	K	1,40	1,60	2,00	2,40	2,70	3,10	3,80	4,60	5,30	6,00
	H m/Gr/t min-max Z m/Gr/t min-max	2,3/1/0,64-1,10 2,4/1/0,82-1,07	2,5/1/1,10-1,40 2,4/1/1,10-1,35	2,7/1/1,30-1,60 2,6/1/1,27-1,52	3,1/1/1,70-2,00 3,0/1/1,68-1,93	4,2/2/1,74-2,24 4,0/2/1,65-2,11	4,6/2/2,04-2,54 4,3/2/1,90-2,36	5,3/2/2,77-3,27 5,0/2/2,64-3,10	6,8/3/3,03-3,53 6,7/3/3,02-3,48	9,0/4/4,18-4,68 8,8/4/4,06-4,52	9,0/4/4,18-4,68 8,8/4/4,06-4,52
KF 1543	D	3,40	3,80	4,70	5,60	6,50	7,50	9,20	11,00	13,60	14,50
	c	0,35	0,35	0,55	0,55	0,55	0,65	0,75	0,85	0,95	0,95
	H m/Gr/t min-max Z m/Gr/t min-max	1,6/0/0,55-0,85 1,6/0/0,56-0,81	2,4/1/1,95-1,25 2,2/1/0,92-1,17	2,7/1/1,25-1,55 2,5/1/1,22-1,47	2,9/1/1,50-1,80 2,8/1/1,48-1,73	3,9/2/1,40-1,90 3,7/2/1,34-1,80	4,4/2/1,90-2,40 4,0/2/1,60-2,06	4,6/2/2,10-2,60 4,4/2/2,05-2,51	6,6/3/2,80-3,30 6,1/3/2,46-2,92	6,9/3/3,02-3,68 6,8/3/3,01-3,47	8,7/4/3,90-4,40 8,5/4/3,86-4,32
KF 1546	SW		4,00	5,00	5,50	6,00	7,00	8,00	10,00	10,00	13,00
	K		1,40	1,70	2,00	2,40	2,80	3,50	4,00	4,80	5,30
KF 1552	D	3,60	4,00	5,00	6,00	7,00	8,00	10,00	12,00	14,00	16,00
	K	1,40	1,60	2,00	2,40	2,70	3,10	3,80	4,60	5,30	6,00
	İç 6 - Yuvarlak A max/t min-max	T6 1,75/0,65-0,80	T6 1,75/0,70-0,85	T8 2,40/0,90-1,15	T10 2,80/1,00-1,30	T15 3,35/1,20-1,50	T20 3,95/1,40-1,80	T25 4,50/1,60-2,00	T30 5,60/2,00-2,40	T40 6,75/2,40-2,90	T40 6,75/2,70-3,20
KF 1553	D	3,40	3,80	4,70	5,60	6,50	7,50	9,20	11,00	13,60	14,50
	c	0,35	0,35	0,55	0,55	0,55	0,65	0,75	0,85	0,95	0,95
	İç 6 - Yuvarlak A max/t min-max f _s	T6 1,75/0,50-0,65 0,40	T6 1,75/0,70-0,85	T8 2,40/0,90-1,15	T10 2,80/1,00-1,30	T15 3,35/1,20-1,50	T20 3,95/1,40-1,80	T25 4,50/1,60-2,00	T30 5,60/2,00-2,40	T40 6,75/2,40-2,90	T40 6,75/2,70-3,20
KF 1523	D	3,40	3,80	4,70	5,50	7,30	8,40	9,30	11,30	13,60	15,80
	c	0,35	0,35	0,55	0,55	0,55	0,65	0,75	0,85	0,95	0,95
	İç 6 - Yuvarlak A max/t min-max	T6 1,75/0,50-0,65	T6 1,75/0,60-0,85	T8 2,40/0,70-0,95	T10 2,80/0,70-1,05	T15 3,35/1,20-1,55	T20 3,95/1,20-1,70	T25 4,50/1,30-1,80	T30 5,60/1,70-2,15	T40 6,75/2,25-2,70	T40 6,75/2,40-2,90

Tüm ölçüler mm.'dir. All dimensions in mm.

Yıldız ve Diğer Formlar / Cross-recessed and Other Forms

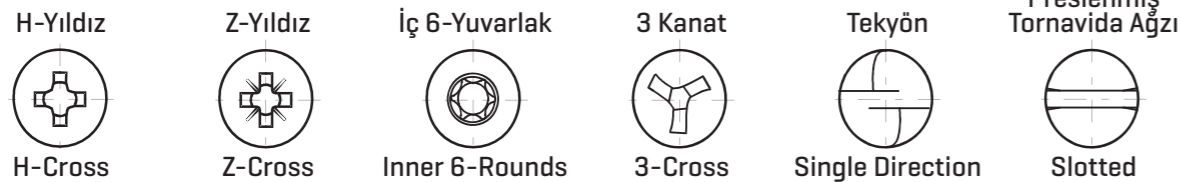

Havşabaş hariç tüm yıldız ve diğer formlar ilave olarak tornavida yarığıyla yapılabilir.
Additional slotted forms available excluding countersunk heads.

Malzeme / Material: 10.9. A2. A4
Kaplama / Coating: Her tür mevcuttur.
All kinds available.

Vida Uçları Screw Ends

